

RoHS Compliance

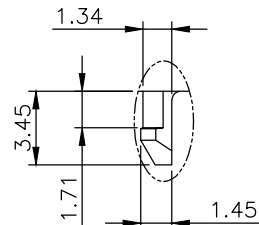

DETAIL Z
SCALE 2:1

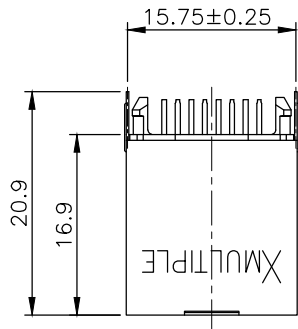
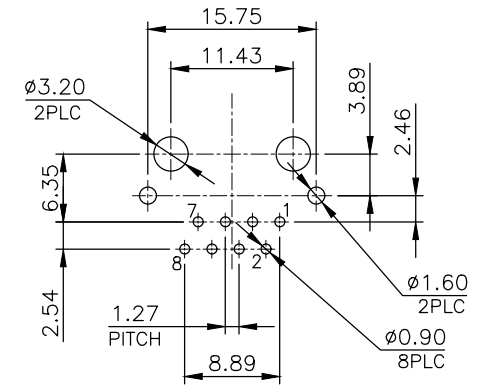
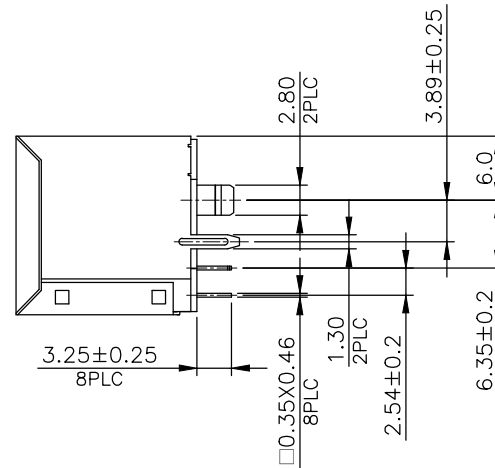
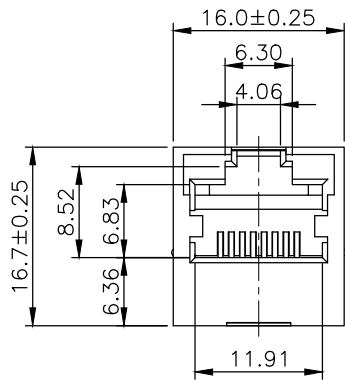

RECOMMENDED PCB LAYOUT
PCB THICKNESS: 1.6mm
TOLERANCE: ±0.05mm (TOP VIEW)

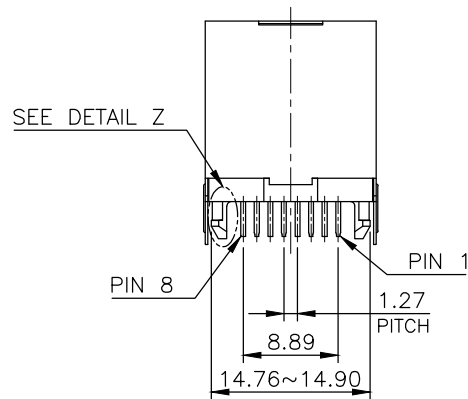

NOTE:

CAVITY CONFIRMS TO FCC RULES AND REGULATIONS PART 68, SUBPART F.

1. MATERIAL:

- 1.1 HOUSING: PBT, WITH GLASS FIBER, UL94V-0, STANDARD COLOR-BLACK.
- 1.2 INSERT HOUSING: PA46, WITH GLASS FIBER, UL94V-0, STANDARD COLOR-BLACK.
- 1.3 CONTACTS: PHOSPHOR BRONZE.
- 1.4 SHELL: BRASS.

2. FINISH:

- 2.1 CONTACTS: 0.381μm [15μ"] GOLD PLATED ON CONTACT AREA, GOLD FLASH ON SOLDER TAIL, 1.27μm [50μ"] MIN. NICKEL UNDERPLATED OVERALL.
- 2.2 SHELL: 0.508μm [20μ"] MIN. NICKEL PLATED.

THIS DRAWING IS A CONTROLLED DOCUMENT.
DO NOT SCALE DRAWING.

DIMENSIONS: MM TOLERANCES UNLESS OTHERWISE SPECIFIED:

0 PLC	±
1 PLC	±0.25
2 PLC	±0.13
3 PLC	±0.05
ANGLES	±

THIRD ANGLE PROJECTION MATERIAL SEE NOTES FINISH SEE NOTES



TITLE RJ45, WITH TRANSFORMER, FLAT PIN, WITHOUT LED, TOP ENTRY PCB JACK

REVISIONS	DESCRIPTION	DATE	APVD

DWN	T. LI	DATE	SEP-11-2014
CHK	D. Wang		SEP-11-2014
APVD	R. Tsai		SEP-12-2014

SIZE	DRAWING NO	WEIGHT	REV	SHEET
A3	XRJV-01V-0-D12-081	- GRAMS Ref.	1	2

