

RoHS Compliance

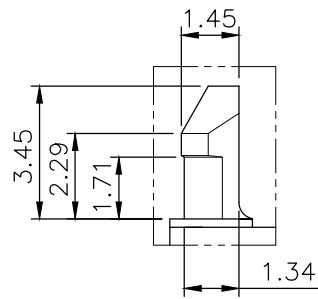

DETAIL X

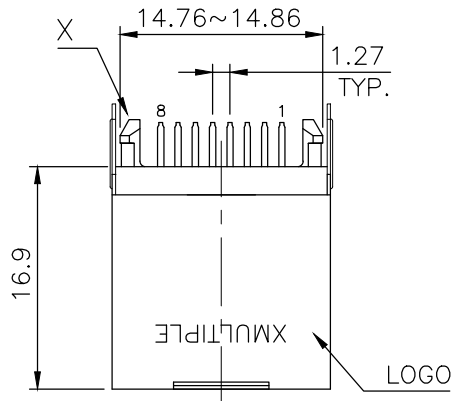
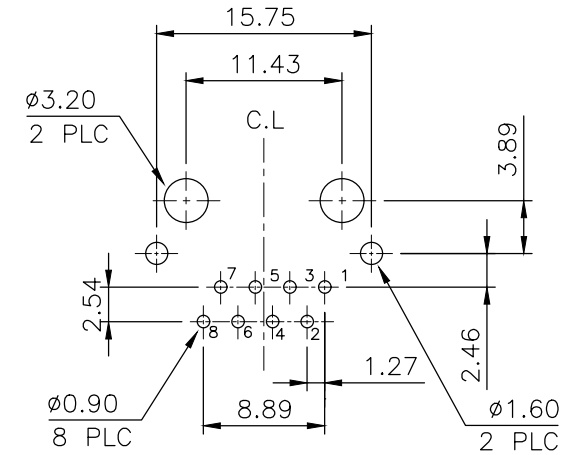
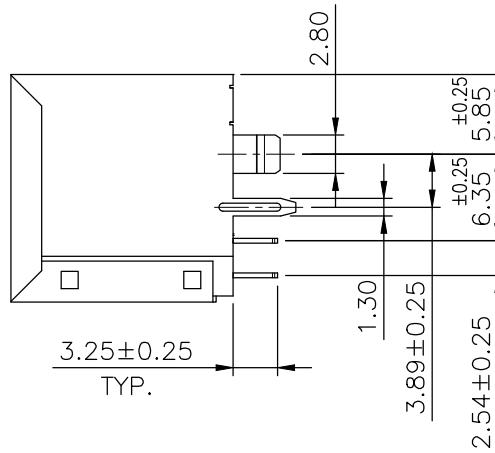
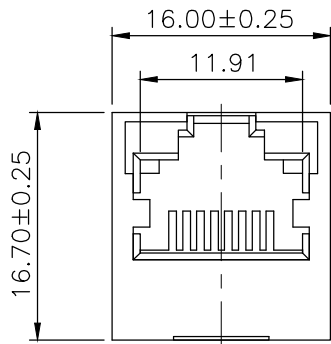

PCB Layout Ref.

- MATERIAL:**
- HOUSING—PBT POLYESTER UL94V-0 MIXED GLASS FIBER. STANDARD COLOR—BLACK
 - CONTACTS—0.35mm THICK PHOS-BRONZE PLATED 30u" WITH HARD GOLD AND TIN IN SOLDER AREA.
 - SHIELD—0.25mm THICK COPPER ALLOY, PLATED WITH NICKEL.

CAVITY CONFIRMS TO FCC RULES AND REGULATIONS PART 68,SUBPART F.

THIS DRAWING IS A CONTROLLED DOCUMENT.
DO NOT SCALE DRAWING.

DIMENSIONS: MM TOLERANCES UNLESS OTHERWISE SPECIFIED:

THIRD ANGLE PROJECTION

MATERIAL SEE NOTES FINISH SEE NOTES

DWN T. LI DATE OCT-04-2018

CHK D. Wang OCT-04-2018

APVD R. Tsai OCT-04-2018



TITLE RJ45, WITHOUT LED, SHIELDED, WITH TRANSFORMER, FLAT PIN, TOP ENTRY PCB JACK

SIZE A3 DRAWING NO XMV-9813-8812-SOT1-B

WEIGHT - GRAMS Ref. REV 2 SHEET 1

REVISIONS	DESCRIPTION	DATE	APVD
△ -			

RoHS Compliance

9813 TRANSFORMER TYPE 1

ELECTRICAL CHARACTERISTICS

TEST NOTES: (25°±5°C)

1. TR: (100KHz, 0.1V)
 PINS:(P6-P5-P4):(J6,J3)=1CT:1CT±3%
 PINS:(P3-P2-P1):(J2,J1)=1CT:1CT±3%
2. INDUCTANCE: (@0.1V, 100KHz, 8mA, DC Bias)
 PINS: (P6-P4),(P3-P1)=350uH MINIMUM
3. DCR:
 PINS: (J6-J3)=(J2-J1)=1.2 OHMS MAXIMUM
4. HIPOT:
 PINS(J1,J2)TO(P1,P3)=1500VAC FOR 60 SECONDS
 PINS(J3,J6)TO(P4,P6)=1500VAC FOR 60 SECONDS
5. LEAKAGE INDUCTANCE:
 P6-P4 (WITH J6 AND J3 SHORT)=0.3 MAXIMUM, @1MHz
 P3-P1 (WITH J2 AND J1 SHORT)=0.3 MAXIMUM, @1MHz
6. INSERTION LOSS:
 -1.1dB MAXIMUM AT 1MHz TO 100MHz
7. RETURN LOSS:
 -18dB MINIMUM AT 1MHz TO 30MHz
 -12dB MINIMUM AT 60MHz TO 80MHz
8. CROSS TALK:
 -30dB MINIMUM AT 1MHz TO 100MHz
9. COMMON TO COMMON MODE ATTENUATION:
 -35dB MINIMUM AT 30MHz TO 100MHz
10. RISE TIME: RS=100 OHMS AND RL=100 OHMS
 OUTPUT VOLTAGE=1 V PEAK=3.0 nS MAXIMUM
 PULSE WIDTH=112 nS=3.0 nS MAXIMUM
11. INTERWINDING CAPACITANCE:
 (P6,P5,P4)TO(J6,J3)=30pF MAXIMUM, @1MHz
 (P3,P2,P1)TO(J2,J1)=30pF MAXIMUM, @1MHz

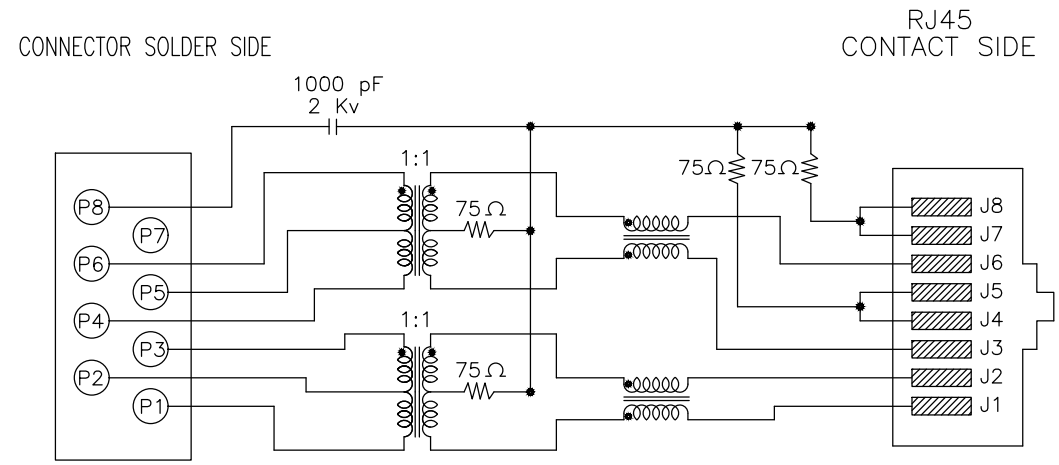

CONNECTOR SCHEMATIC

THIS DRAWING IS A CONTROLLED DOCUMENT. DO NOT SCALE DRAWING.	
DIMENSIONS: MM	TOLERANCES UNLESS OTHERWISE SPECIFIED:
	X ± - X.X ± - X.XX ± - X.XXX ± - ANGLES ± -
THIRD ANGLE PROJECTION	
MATERIAL SEE NOTES	FINISH SEE NOTES
DWN <i>T. Li</i>	DATE OCT-04-2018
CHK <i>D. Wang</i>	OCT-04-2018
APVD <i>R. Tsai</i>	OCT-04-2018



TITLE RJ45, WITHOUT LED, SHIELDED, WITH TRANSFORMER, FLAT PIN, TOP ENTRY PCB JACK	
SIZE A3	DRAWING NO XMV-9813-8812-S0T1-B
WEIGHT - GRAMS Ref.	REV - SHEET 2

REVISIONS	DESCRIPTION	DATE	APVD