

REV	ZONE	REVISION	DATE

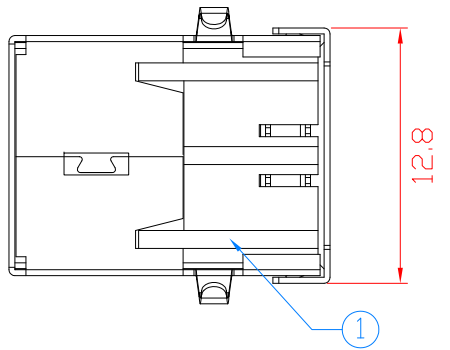
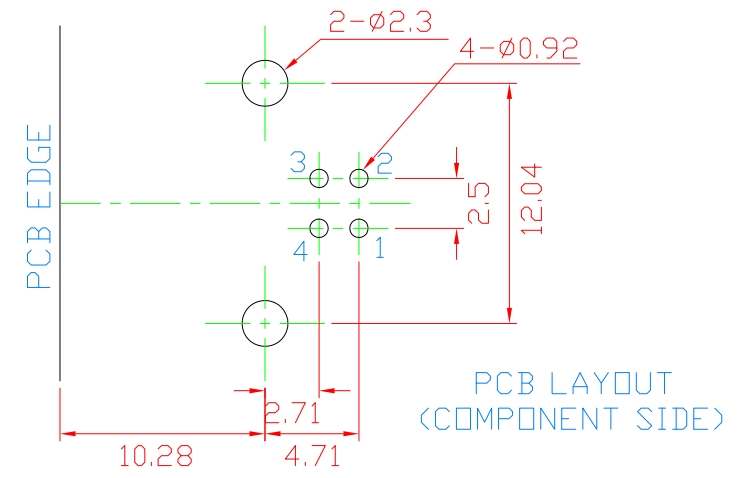
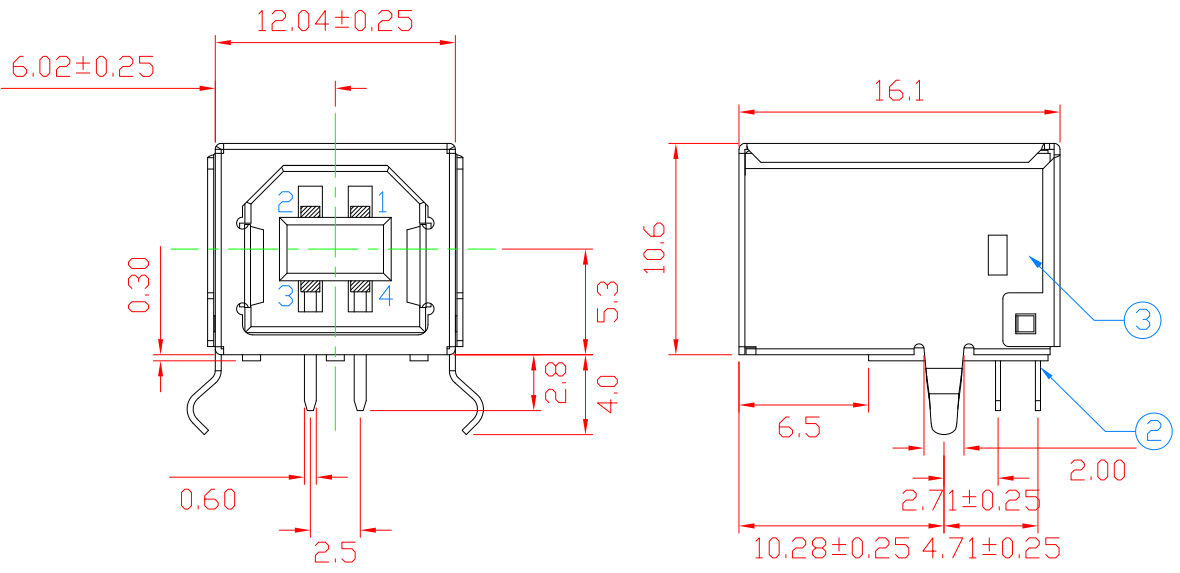

Specification:
Contact Resistance: 30m Ohm Max.
Insulation Resistance: 1000M Ohm Min. At 500VDC.
Rated Voltage And Current: 1.5A At 250VAC Minimum.
Dielectric Withstanding Voltage:
 750V AC (rms) for 1 Minute(Rev. 1.1)
Durability (Life Test): 1500 Cycles
Insertion Force: 35 Newton Maximum.
Extraction Force: 10 Newton Minimum.

Green Product

NO.	NAME	MATERIAL	FINISH	REMARK	Q'TY
1	HOUSING	PBT G.F.	WHITE		1
2	PIN TERM.	PHOS. BRONZE T:0.25	GOLD/TIN PLATED	Gold:1~3u"; NI:40~60u"; TIN:120u" (100% pure Tin of lead free plating)	4
3	SHELL	BRASS T:0.3	NICKEL PLATED	NI:80~120u"	1

Xmultiple Technologies, Inc.

MODEL XUS-KS-001-BNW-L PAGE 1 OF 1

COMPUTER NO.			UNIT	SCALE	PART NAME	
APPD.	CKD.	DWG.	mm	1:1	USB B TYPE FLAT 4 PIN DIP	
		TINA	DATE	TOLERANCE	PART NO.	REV.
			05-03-10	X. ±0.38 .X ±0.25 .XX ±0.13 .XXX ±0.05		A0