



XSFP-T-FO13-1101 SFP with Digital Diagnostic Interface



Features

- SFP Multi-Source Agreement Compliant
- Compliant with IEEE802.3z Gigabit Ethernet standard
- Serial ID functionality support
- Duplex LC receptacle connector
- Single power supply 3.3V
- 1310nm FP Laser
- Hot Pluggable
- Low power dissipation
- Class 1 laser safety standard IEC825 compliant

Application

- 1x Fiber Channel
- Gigabit Ethernet
- High speed I/O for file server
- Bus extension application
- Channel extender, Data storage system

Product Overview

The XSFP-T-FO13-1101 of Small Form Factor Pluggable (SFP) transceiver module is specifically designed for the high performance integrated duplex data link over single-mode optical fiber. These transceiver modules are compliant with the SFP Multisource Agreement (MSA). With the hot pluggability, these modules offer an easy way to be installed into SFP MSA compliant ports at any time without the interruption of the host equipments operating online.

The XSFP-T-FO13-1101 SFP transceivers using a long wavelength (1310nm) FP laser diode enable data transmission up to 10km on a single mode (9/125 μ m) optical fiber.



XSFP-T-FO13-1101 SFP with Digital Diagnostic Interface

Absolute Maximum Ratings

PARAMETER	SYMBOL	MIN	MAX	UNITS	NOTE
Storage Temperature	T_S	-40	+85	°C	
Supply Voltage	V_{CC}	-0.5	4.5	V	
Storage Relative Humidity	RH	5	95	%	

Recommended Operating Conditions

PARAMETER	SYMBOL	MIN	TYP.	MAX	UNITS	NOTE
Case Operating Temperature	T_C	0	---	70	°C	
Supply Voltage	V_{CC}	3.1	3.3	3.5	V	
Supply Current	$I_{TX} + I_{RX}$	---	180	300	mA	

Transmitter Electro-optical Interface

PARAMETER	SYMBOL	MIN	TYP.	MAX	UNITS	NOTE
Output Optical Power	P_{out}	-9.5	---	-3	dBm	1
Optical Extinction Ratio	ER	9	---	---	dB	
Center Wavelength	λ_C	1285	1310	1343	nm	
Spectral Width (RMS)	$\Delta\lambda$	---	---	2.8	nm	
Optical Rise/Fall Time	T_r/T_f	---	---	260	ps	2
Relative Intensity Noise	RIN	---	---	-120	dB/Hz	
Total Jitter	TJ	---	---	227	ps	
Max. P_{out} TX-DISABLE Asserted	P_{OFF}	---	---	-45	dBm	
Differential Input Voltage	TD +/-	400	---	2400	mV	
Tx_Fault - High	V_{Fault_H}	2		V_{CC}	V	
Tx_Fault - Low	V_{Fault_L}	V_{EE}		$V_{EE}+0.8$	V	
Tx_Disable - High	$V_{Disable_H}$	2		V_{CC}	V	
Tx_Disable - Low	$V_{Disable_L}$	V_{EE}		$V_{EE}+0.8$	V	

Note 1: Coupling into a 9/125µm single-mode fiber.

Note 2: 20% to 80% value

XSFP-T-FO13-1101 SFP with Digital Diagnostic Interface

Receiver Electro-optical Interface

PARAMETER	SYMBOL	MIN	TYP.	MAX	UNITS	NOTE
Receiver Overload	P_{INMAX}	-3	---	---	dBm	1
Receiver Sensitivity	P_{INMIN}	---	---	-20	dBm	1
Operating Center Wavelength	λ_C	1270	---	1355	nm	
Optical Return Loss	ORL	12	---	---	dB	
Differential Output Voltage	$RD \ +/-$	400	---	2000	mV	
Receiver Loss of Signal – TTL Low	P_{RX_LOSD}	---	---	-20	dBm	
Receiver Loss of Signal – TTL High	P_{RX_LOSA}	-35	---	---	dBm	
Receiver Loss of Signal – Hysteresis	P_{RX_LOSH}	0.5	---	---	dB	

Note 1: With BER better than or equal to 1×10^{-12} , measured in the center of the eye opening with 2^7-1 PRBS.

Block diagram

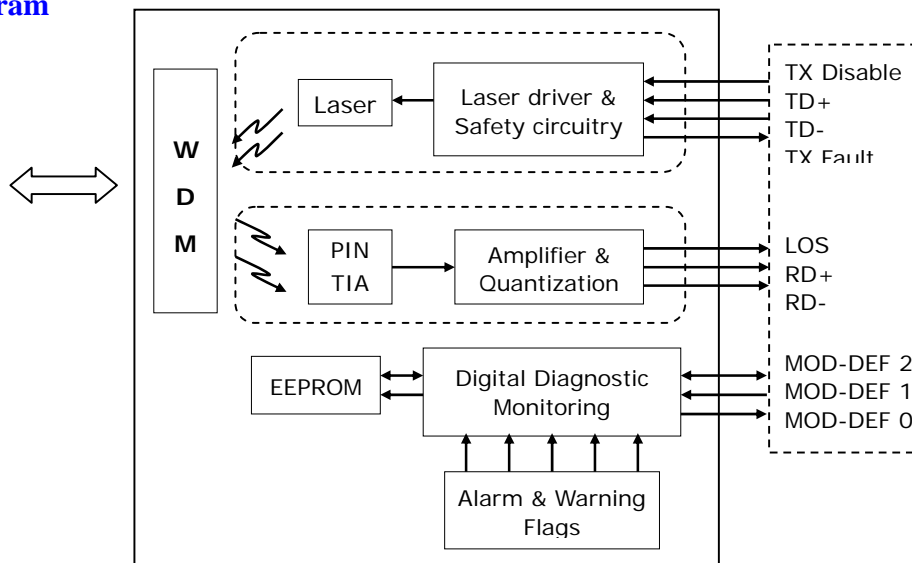

The transceiver is fundamentally consisted by two parts: transmitter and receiver. The transmitter features a TTL logic level Disable signal and a Fault indicator. The receiver features a TTL logic Loss of Signal (LOS) detection. The serial ID interface defines a 256-byte memory map in EEPROM, accessible over a 2 wire, serial interface at the 8 bit address 1010000X (A0h). The Digital Diagnostic Monitoring Interface makes use of the 8 bit address 1010001X (A2h), so the originally defined serial ID memory map remains unchanged and is therefore backward compatible. The detailed signal descriptions are listed in the following sections.



XSFP-T-FO13-1101 SFP with Digital Diagnostic Interface

Digital Diagnostic Memory Map

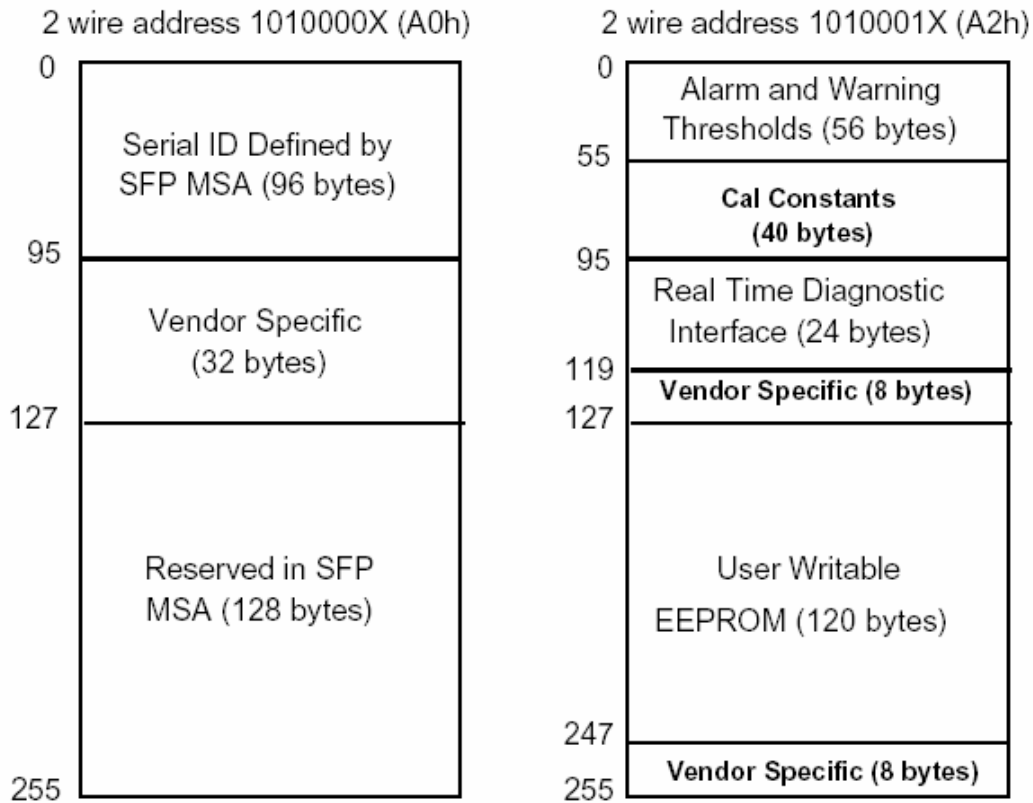

Digital Diagnostic Monitoring Characteristics

Parameter	Symbol	Accuracy	Unit	Note
Transceiver Temperature	T_{INT}	± 3	$^{\circ}C$	
Transceiver Supply Voltage	V_{INT}	± 3	%	
TX Bias Current	I_{BIAS}	± 10	%	
TX Output Power	P_{TX}	± 3	dB	
RX Received Optical Power	P_{RX}	± 3	dB	

XSFP-T-FO13-1101 SFP with Digital Diagnostic Interface

Pin Description

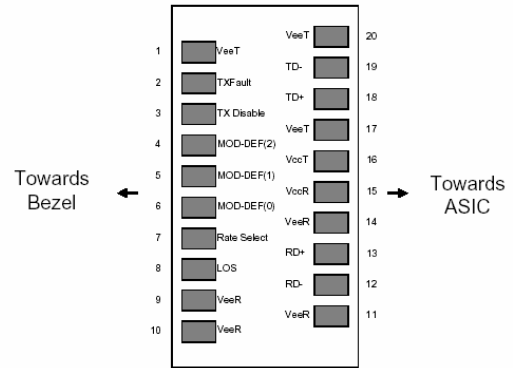
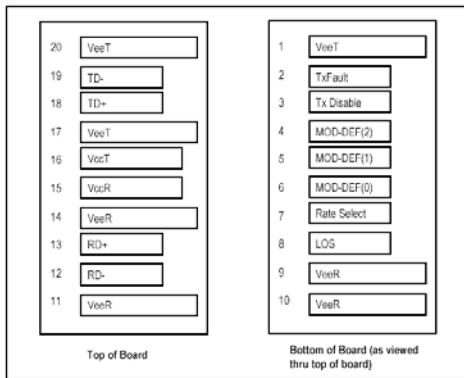

Diagram of Host Board Connector Block Pin

SFP Transceiver Electric Pad Layout

Numbers and Names

Pin No	Pin Name	Function	Plug Seq.	Notes
1	VeeT	Transmitter Ground	1	
2	TX Fault	Transmitter Fault Indication	3	1
3	TX Disable	Transmitter Disable	3	2
4	MOD-DEF 2	Module Definition 2	3	3
5	MOD-DEF 1	Module Definition 1	3	3
6	MOD-DEF 0	Module Definition 0	3	3
7	Rate Select	Select between full or reduced receiver bandwidth	3	4
8	LOS	Loss of Signal	3	5
9	VeeR	Receiver Ground	1	6
10	VeeR	Receiver Ground	1	6
11	VeeR	Receiver Ground	1	6
12	RD-	Inv. Received Data Out	3	7
13	RD+	Received Data Out	3	7
14	VeeR	Receiver Ground	1	6
15	VccR	Receiver Power	2	8
16	VccT	Transmitter Power	2	8
17	VeeT	Transmitter Ground	1	6
18	TD+	Transmit Data In	3	9
19	TD-	Inv. Transmit Data In	3	9
20	VeeT	Transmitter Ground	1	6



XSFP-T-FO13-1101 SFP with Digital Diagnostic Interface

Notes:

Plug Seq.: Pin engagement sequence during hot plugging.

1. TX Fault is an open collector/drain output, which should be pulled up with a 4.7K – 10K Ω resistor on the host board. Pull up voltage between 2.0V and VccT, R+0.3V. When high, output indicates a laser fault of some kind. Low indicates normal operation. In the low state, the output will be pulled to < 0.8V.
2. TX disable is an input that is used to shut down the transmitter optical output. It is pulled up within the module with a 4.7 – 10 K Ω resistor. Its states are:
Low (0 – 0.8V): Transmitter on
(>0.8, < 2.0V): Undefined
High (2.0 – 3.465V): Transmitter Disabled
Open: Transmitter Disabled
3. Mod-Def 0,1,2. These are the module definition pins. They should be pulled up with a 4.7K - 10K Ω resistor on the host board. The pull-up voltage shall be VccT or VccR
Mod-Def 0 is grounded by the module to indicate that the module is present
Mod-Def 1 is the clock line of two wire serial interface for serial ID
Mod-Def 2 is the data line of two wire serial interface for serial ID
4. This is an optional input used to control the receiver bandwidth for compatibility with multiple data rates (most likely Fiber Channel 1x and 2x Rates). If implemented, the input will be internally pulled down with > 30k Ω resistor. The input states are:
Low (0 - 0.8V): Reduced Bandwidth
(>0.8 , < 2.0V): Undefined
High (2.0 V -3.465V): Full Bandwidth
Open: Reduced Bandwidth
5. LOS (Loss of Signal) is an open collector/drain output, which should be pulled up with a 4.7K -10K Ω resistor. Pull up voltage between 2.0V and VccT, R+0.3V. When high, this output indicates the received optical power is below the worst-case receiver sensitivity (as defined by the standard in use). Low indicates normal operation. In the low state, the output will be pulled to < 0.8V.
6. VeeR and VeeT may be internally connected within the SFP module.
7. RD-/+ : These are the differential receiver outputs. They are AC coupled 100 Ω differential lines which should be terminated with 100 Ω (differential) at the user SERDES. The AC coupling is done inside the module and is thus not required on the host board. The voltage swing on these lines will be between 370 and 2000 mV differential (185 - 1000 mV single ended) when properly terminated.
8. VccR and VccT are the receiver and transmitter power supplies. They are defined as 3.3V \pm 5% at the SFP connector pin. Maximum supply current is 300 mA. Recommended host board power supply filtering is shown below. Inductors with DC resistance of less than 1 Ω should be used in order to maintain the required voltage at the SFP input pin with 3.3V supply voltage. When the recommended supply filtering network is used, hot plugging of the SFP transceiver module will result in an inrush current of no more than 30 mA greater than the steady state value. VccR and VccT may be internally connected within the SFP transceiver module.
9. TD-/+ : These are the differential transmitter inputs. They are AC-coupled, differential lines with 100 Ω differential termination inside the module. The AC coupling is done inside the module and is thus not required on the host board. The inputs will accept differential swings of 500 mV - 2400 mV (250 mV - 1200 mV single-ended), though it is recommended that values between 500 and 1200 mV differential (250 mV- 600 mV single-ended) be used for best EMI performance.



XSFP-T-FO13-1101 SFP with Digital Diagnostic Interface

Mechanical Dimensions (Units in mm):

