

# RoHS Compliance

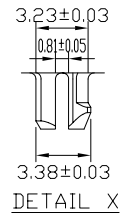

- MATERIALS:
- HOUSING-DSM STANYL TE250F6 (NYLON-46)  
HEAT DEFLECTION TEMP.290°  
BLACK COLOR, UL94V-0
  - CONTACTS-0.35mm THICK PHOS-BRONZE PLATED  
WITH HARD GOLD AND GOLD FLASH IN  
SOLDER AREA.
  - SHIELD-0.25mm THICK COPPER ALLOY,  
PLATED WITH NICKEL.
- CAVITY CONFIRMS TO FCC RULES AND REGULATIONS  
PART 68,SUBPART F.

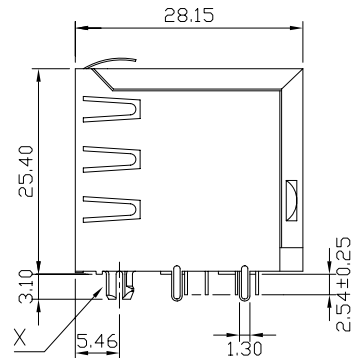
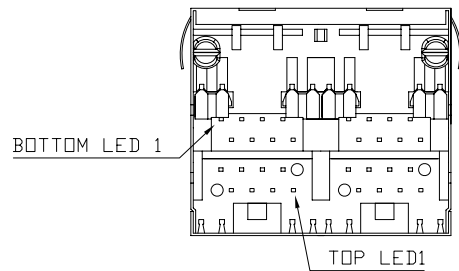
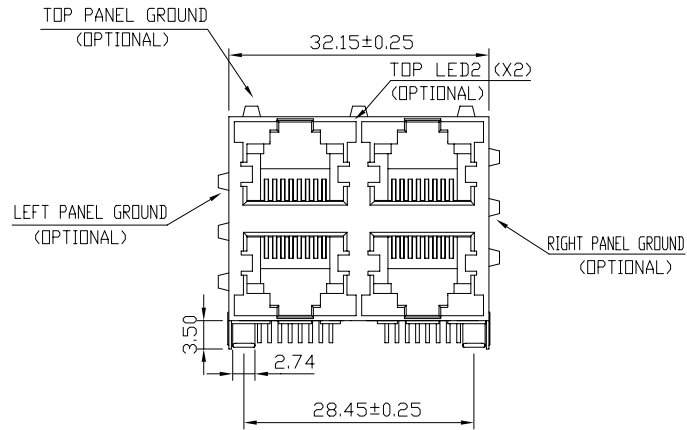
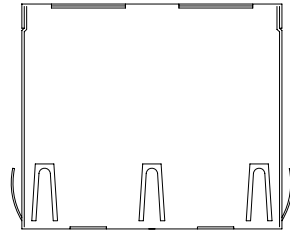
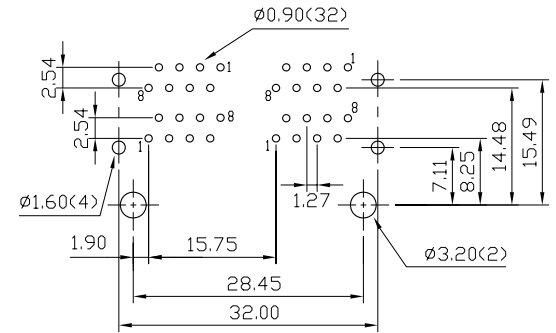

DO NOT SCALE DRAWING	TOLERANCES UNLESS OTHERWISE NOTED	INCH	MM	DR. <i>M.L.HUANG</i>	DATE MAR-09 '10	<i><b>XMULTIPLE</b></i>	
THIRD ANGLE PROJECTION	LINEAR $\frac{\text{MM}}{\text{INCH}}$	$00 \pm .01$ $000 \pm .005$ $0000 \pm .002$	$0.0 \pm 0.25$ $0.00 \pm 0.13$ $0.000 \pm 0.05$	CK'D <i>M.CHANG</i>	MAR-09 '10		TITLE 2X2 STACKABLE MODULAR JACK RJ45, WITH LED'S AND SHIELD
MM INCH	ANGLE $\pm 0^{\circ} 30'$	RADII	$+ 0.40$ $- 0.15$	APP'D <i>W.J.YANG</i>	MAR-09 '10		SCALE SIZE DWG.NO. XMD-9766-881X-4-S3-LFG-AAS