

RoHS Compliance

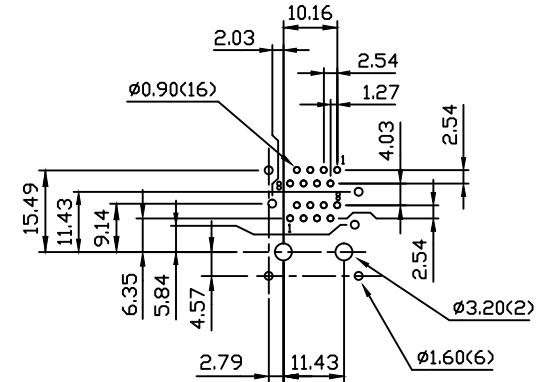
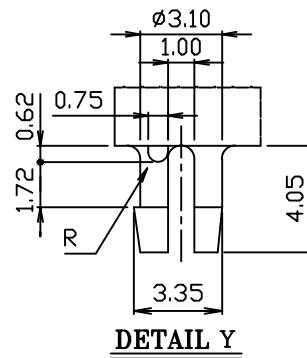
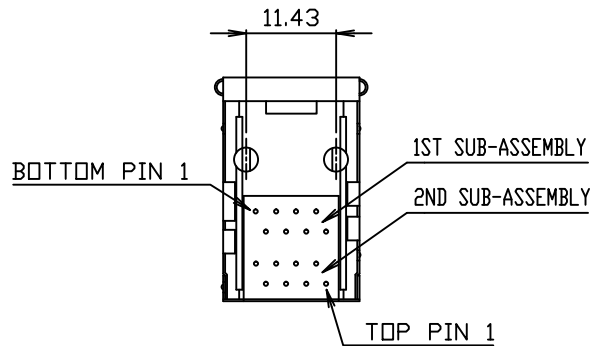
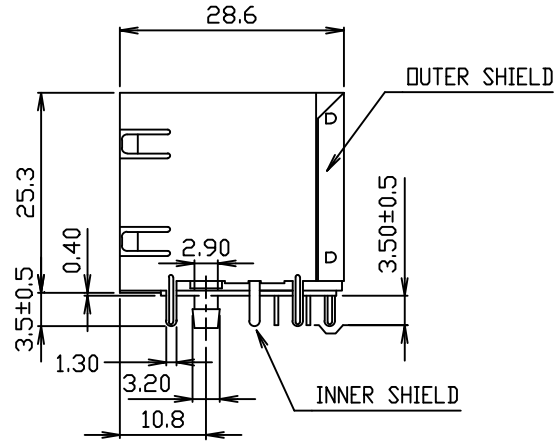
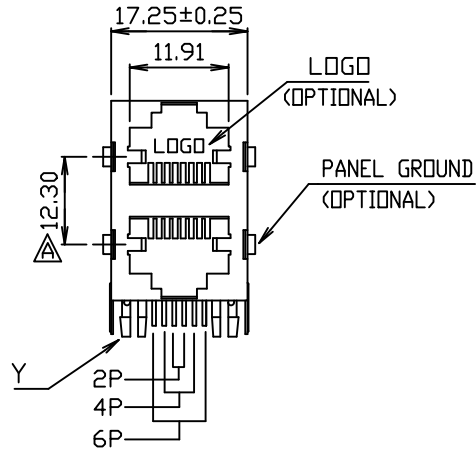

PCB LAYOUT Ref.

MATERIAL:

- HOUSING-PBT POLYESTER UL-94V-0 MIXED GLASS FIBER. STANDARD COLOR-BLACK
- CONTACTS-0.35mm THICK PHOS-BRONZE PLATED WITH 15u HARD GOLD AND GOLD FLASH IN SOLDER AREA.
- SHIELD-0.20mm THICK COPPER ALLOY, PLATED WITH NICKEL.

CAVITY CONFIRMS TO FCC RULES AND REGULATIONS PART 68,SUBPART F.

DO NOT SCALE DRAWING	TOLERANCES UNLESS OTHERWISE NOTED	INCH	MM	DR. <i>CIAN.CI.LUO</i>	DATE NOV-24 '09	<i>XMULTIPLE</i>
THIRD ANGLE PROJECTION	LINEAR MM INCH	00 ± .01 000 ± .005 0000 ± .002	0.0 ± 0.25 0.00 ± 0.13 0.000 ± 0.05	CK'D <i>M.CHANG</i>	NOV-24 '09	
MM INCH	ANGLE ± 0° 30'	RADII	+ 0.40 - 0.15	APP'D <i>W.J.YANG</i>	NOV-25 '09	SCALE SIZE DWG.NO. XMD-9731-8811-2AA-D