

一、Mechanicals Dimensions

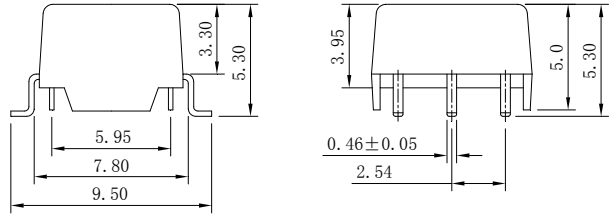

SUGGESTED PAD LAYOUT

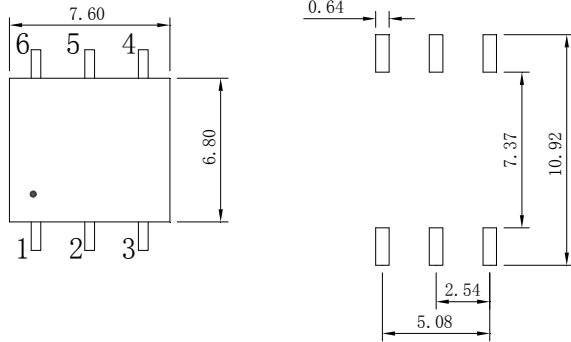

UNIT:mm Unless otherwise specified.all tolerances are±0.25

二、Schematics

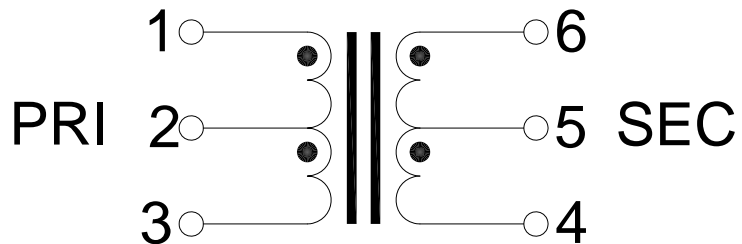

三、ELECTRICAL SPECIFICATIONS@25°C:

1. Turn Ratio(±2%):1CT:2CT
2. Pri OCL(100KHz/0.1V): 1.2mH TYP.
3. Pri LL (100KHz/0.1V):0.4uH MAX
4. CWW (100KHz/0.1V):30pF MAX
5. Pri DCR:0.7Ω MAX
6. HI-POT:1500Vrms/0.5mA/2Sec
7. Operating Temperature: 0°C TO +70°C.
8. RoHS compliance:YES

Ref:TG08-1205NSRL

	Xmultiple Technologies			
	TITLE	TRANSFORMER		
	P/N	XF-15TB-1222XMNL	REV.	0
	PAGE NO	1-4	DATE	2009-11-05
	AP'PD	Li YueSheng	DWN	Hu XiaoLan

REV.	DESCRIPTION	DATE	DWN	AP'PD

四、 Our RoHS parts just can withstand IR Reflow peak temperature: 245degC+/-5degC as the following profile:

REV.	DESCRIPTION	DATE	DWN	AP'PD

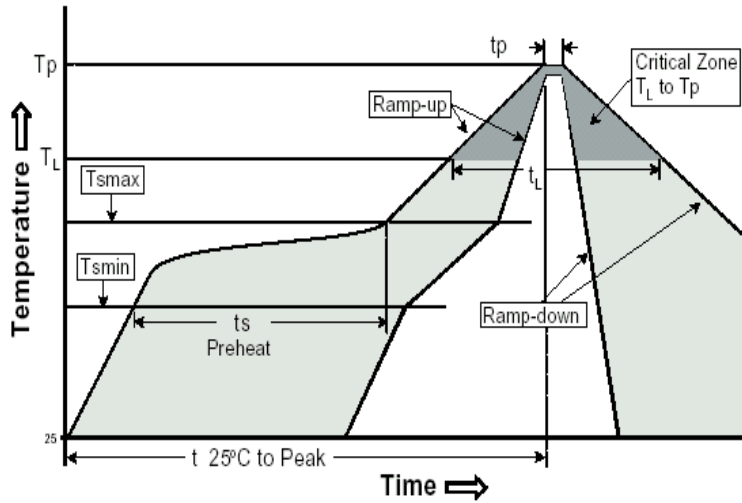
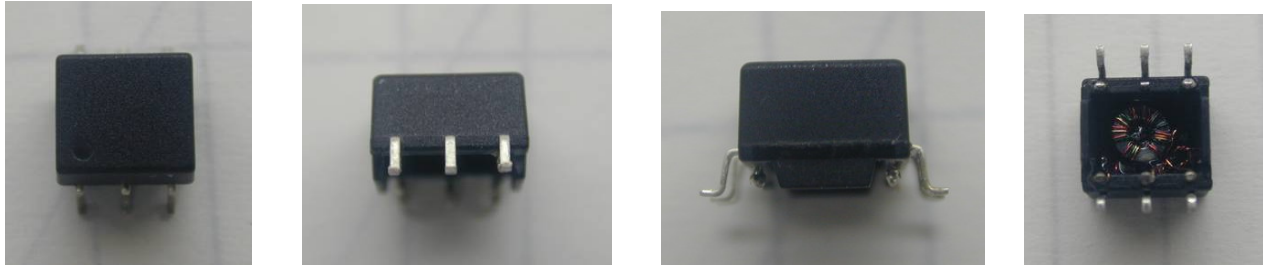

Profile Feature	Pb-Free Assembly
Average Ramp-Up Rate ($T_{s\ max}$ to T_p)	3°C /second max.
Preheat	
-Temperature Min ($T_{s\ min}$)	150°C
-Temperature Max ($T_{s\ max}$)	200°C
-Time ($t_{s\ min}$ to $t_{s\ max}$)	60-180 seconds
Time maintained above:	
-Temperature (T_L)	217°C
-Time (t_L)	60-150 seconds
Peak/Classification Temperature (T_p)	245±5°C
Time within 5°C of actual Peak Temperature (t_p)	20-40 seconds
Ramp-Down Rate	6°C/seconds max
Time 25°C to Peak Temperature	6 minutes max.



Xmultiple Technologies

TITLE	TRANSFORMER		
P/N	XF-15TB-1222XMNL	REV.	0
PAGE NO	2-4	DATE	2009-11-05
AP'PD	Li YueSheng	DWN	Hu XiaoLan

五、 Packing Information:

REV.	DESCRIPTION	DATE	DWN	AP'PD

- 1.Weight-----0.44 grams/pcs
- 2.Tape & Reel----- 800 pcs
3. outer carton unit: 8000pcs/box
4. outer carton unit: 10 T&R/box
- 5.Weight: 9.1kg per carton

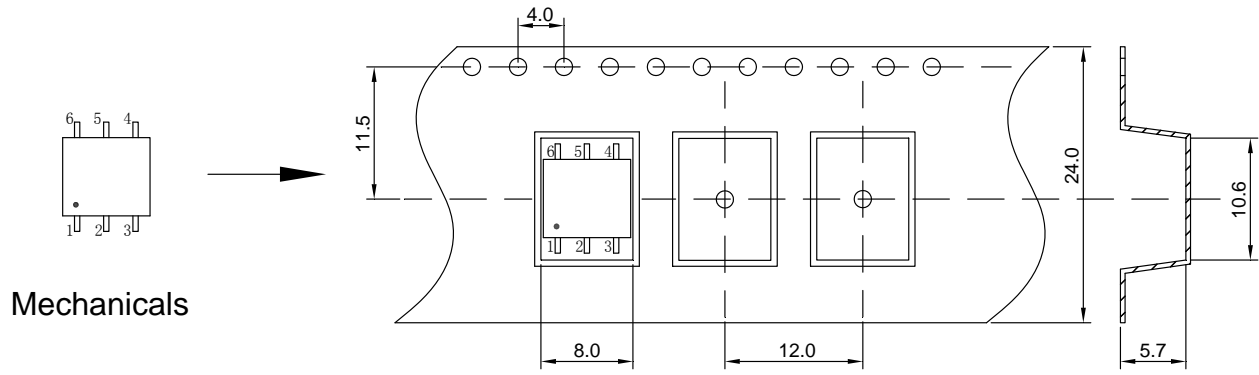

Mechanicals

Tape & Reel

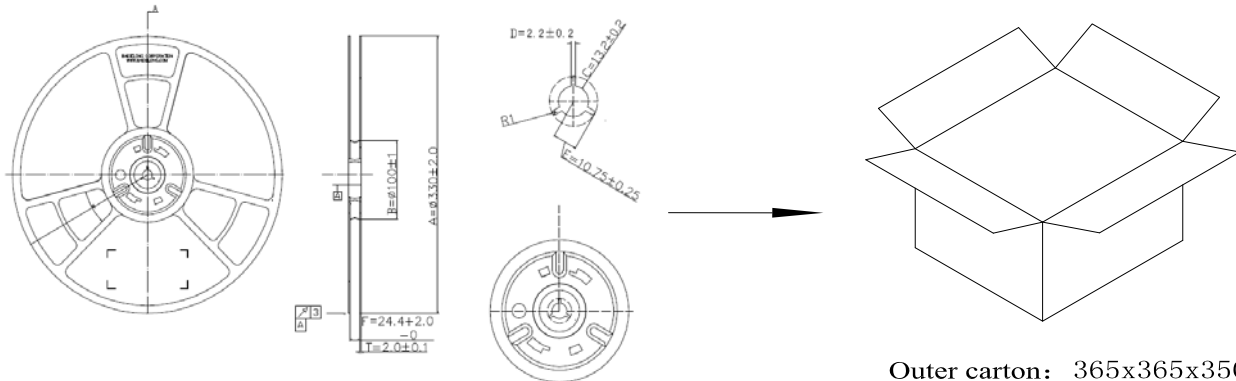

Outer carton: 365x365x350mm



Xmultiple Technologies

TITLE	TRANSFORMER		
P/N	XF-15TB-1222XMNL	REV.	0
PAGE NO	3-4	DATE	2009-11-05
AP'PD	Li YueSheng	DWN	Hu XiaoLan

六、 Packing Information:

REV.	DESCRIPTION	DATE	DWN	AP'PD

1.Weight----- 0.44grams/pcs

2. TUBE ----- 62pcs

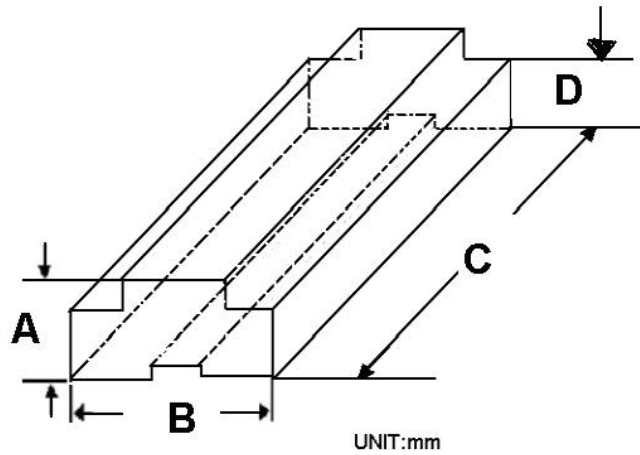

Size(mm)			
A	B	C	D
9.20	13.70	485.0	6.0

3. outer carton unit: 6200pcs/box

4. outer carton unit: 100Tube /box

5.Weight: 5.3kg per carton

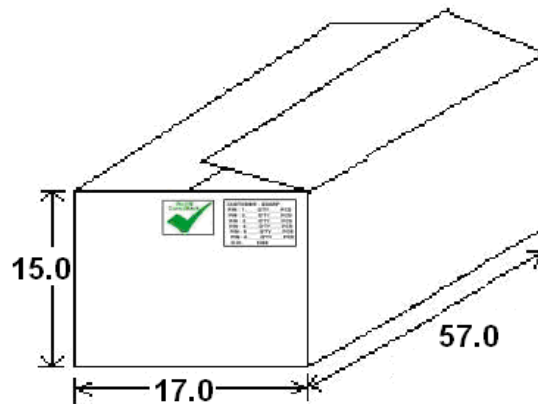

Xmultiple Technologies

TITLE

TRANSFORMER

P/N

XF-15TB-1222XMNL

REV.

0

PAGE NO

4-4

DATE

2009-11-05

AP'PD

Li YueSheng

DWN

Hu XiaoLan