

变更标记	日期	变更内容	签名	核准
A0	09.04.12	新版发行		

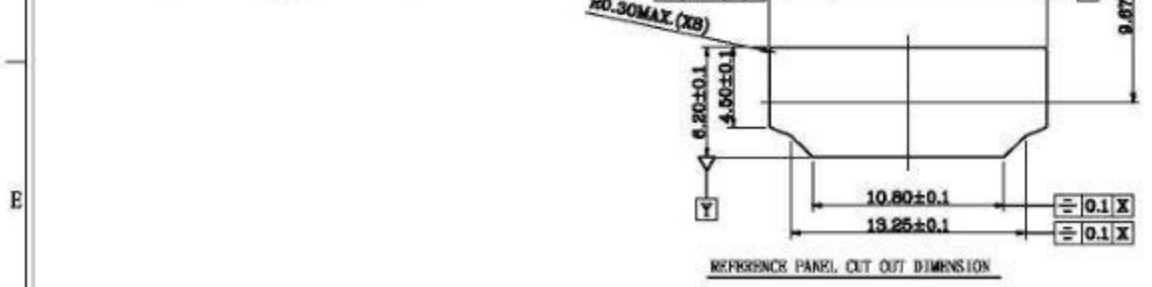
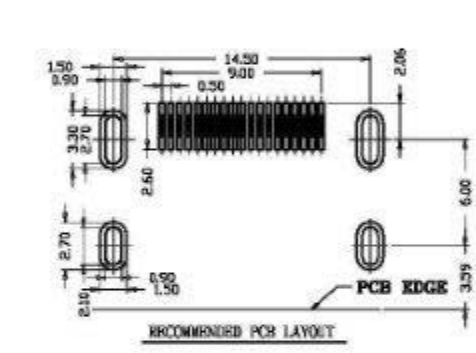
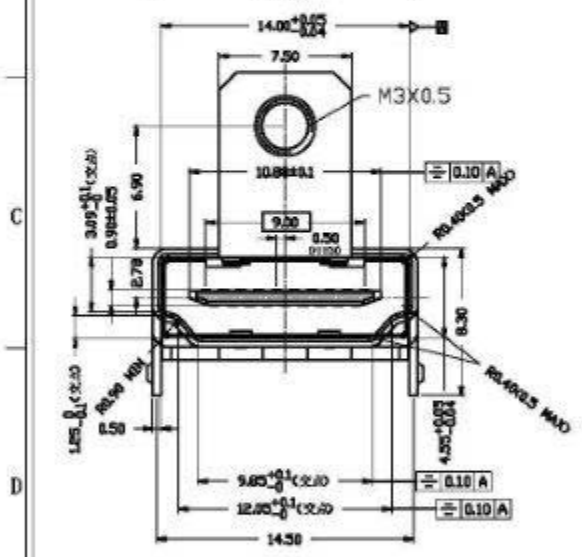
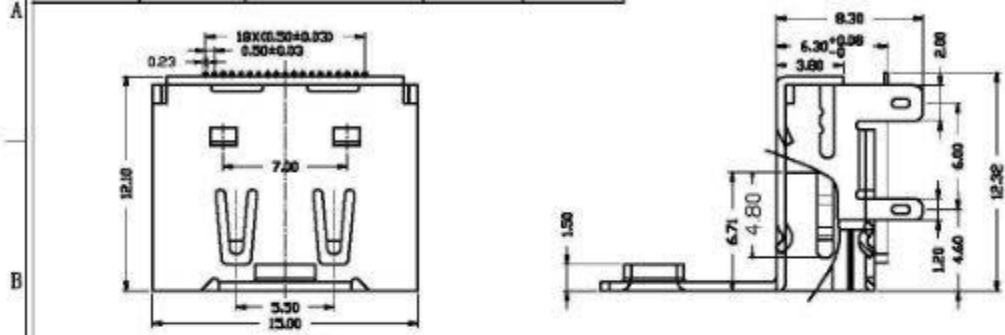

SPECIFICATION

- Electrical characteristics
 - Contact Current Rating: 0.5 A
 - Dielectric Withstanding Voltage: 300V AC
 - Insulation Resistance: a. Mate 100MΩ MIN at 500V/DC
b. Unmate 10MΩ MIN at 150V/DC
 - Contact Resistance: 30mΩ MAX
 - Temperature Range: -20° C to +85° C
- Mechanical
 - Mating Face: 44.1N MAX
 - Unmating Face: 9.8N MIN; 39.2N MAX
 - Durability: 5000 Cycles MIN
- material:
 - HOUSING: THERMOPLASTICS HIGH TEMP LCP+GLASS
FIBER BLACK COLOR, UL94V-0
 - CONTACT: Copper Alloy, T=0.20MM
 - SHELL: Copper Alloy, T=0.50MM
- PLATING:
 - CONTACT: 15u" GOLD/TIN PLATING ON CONTACT AREA
100u" MIN, TIN PLATING ON SOLDER TAILS
50u" MIN, NICKEL UNDERPLATING OVER ALL
 - SHELL: 100u" MIN, BLACK NICKEL UNDERPLATING OVER ALL

XMULTIPLE TECHNOLOGIES, INC.

PART NO:		XHDMI-F19S2-03-MW-ENQ			
未注公差	设计	日期	2009.04.12		HDMI 19P FEMALE
X ±0.25					DIP 有耳无壳
X.X ±0.20				PN	HDMI7006
X.XX ±0.10					
X.XXX ±0.05					
X." ±2" X.X" ±1"					
			1:1		A/0